



PD2SYS-96 SERIES

HEATED DISPLAY SYSTEMS



PD2SYS-96

- HALO HEAT ... a controlled, uniform heat source that gently holds and surrounds food for better appearance, taste, and longer holding life.

- Holds and displays hot food fresh and moist for hours — without adding water.

- Expandable system to meet your specific requirements.

- Matches profile of leading refrigerated display case.

- **HOT DISPLAY CASE**

- Curved glass styling.
- Displays hot food without condensation on glass.
- Thermostatically controlled heat source radiates from the base of the display case in multiple heat zones.
- Overhead light zones with shatterproof coated bulbs.
- Holds a full range of standard (gastronorm) pan sizes, full-size or half-size sheet pans.
- Tempered sliding glass doors reflect heat back into the products and mirror the display to enhance merchandising effect.

- **DECORATOR BASE**

- Standard black painted front and end panels.

The display case is constructed of 18 gauge, non-magnetic stainless steel and is mounted directly on top of two pedestal risers. A curved, tempered glass front encloses the display case and can be lifted to a 90 degree angle for easy cleaning. Removable, sliding glass doors on the operator side are included. Sliding door tracks have a "clean sweep" cutout allowing for easy cleaning and crumb removal. Framed end glass with rubber gasket material protects glass edges from chipping and breakage. The base is divided into three (3) individually managed heat zones with each zone controlled by a separate thermostat with a range of 1 through 10 and heat-on indicator light. Overhead lights are controlled by ON/OFF switches in three (3) light zones. Two (2) 125V plug outlets are available as an option on 120/208-240V units only.

PD2SYS-96 - 96" (2438mm) length

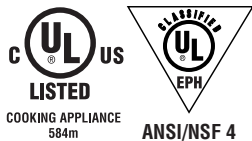

FACTORY INSTALLED OPTIONS

- Panel Color Choices
 - ➔ Specify color choice:
 - Black, standard
 - Stainless Steel, optional
 - Custom Color, optional



W164 N9221 Water Street • P.O. Box 450 • Menomonee Falls, Wisconsin 53052-0450 • U.S.A.
 PHONE: 262.251.3800 800.558.8744 U.S.A./CANADA FAX: 262.251.7067 800.329.8744 U.S.A. ONLY

www.alto-shaam.com

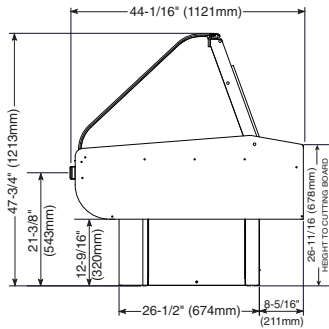

PD2SYS Profile

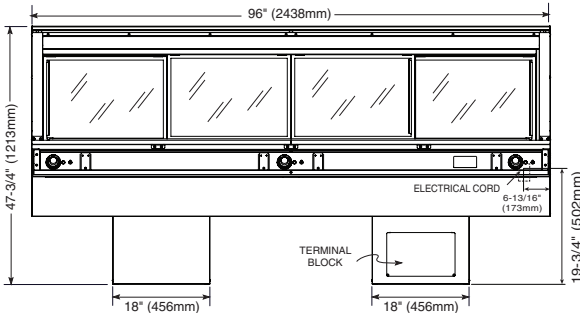

PD2SYS-96

DIMENSIONS (H X W X D)	
EXTERIOR, WITH PEDESTAL STYLE BASE: 47-3/4" x 96" x 44-1/16" (1213mm x 2438mm x 1121mm)	
WELL DIMENSIONS (W X L X D): 27-3/16" x 93-5/16" x 4-1/2" (690mm x 2370mm x 114mm)	

ELECTRICAL					
VOLTAGE	PHASE	CYCLE/HZ	AMPS	kW	
120/208-240 (UL)	1	50/60	24.0	5.2	
at 208	1	50/60	24.0	5.2	BARE END, NO PLUG
at 240	1	50/60	24.0	5.2	
230 (CE)	1	50/60	24.3	5.6	
230	1	50/60	24.7	5.7	BARE END, NO PLUG

PAN CONFIGURATION*			
PAN SIZE	DIMENSIONS	QTY.	
FULL-SIZE & ONE-THIRD**:	12" x 20" x 2-1/2" (GN 1/1)	7	
	12" x 6" x 2-1/2" (GN 1/3)	7	
HALF-SIZE & ONE-THIRD**:	12" x 10" x 2-1/2" (GN 1/2)	14	
	12" x 6" x 2-1/2" (GN 1/3)	7	
FULL-SIZE SHEET PANS:	18" x 26" x 1"	4	
MAX. CAPACITY/VOLUME:	112 lbs (51 kg) 70 qts (84 L)		
* Pans are not included with display case. ** Will also accept 4" (100mm) deep pans.			

SPECIFICATIONS	
<ul style="list-style-type: none"> Fourteen (14) overhead lights in three (3) light zones. Three (3) base heat zones with three (3) adjustable thermostats with a range of 1 through 10, and three (3) heat-on indicator lights. Four (4) tinted, reflective, tempered glass sliding doors on operator side. Two (2) 10" x 36" (254mm x 914mm) operator-side work shelves. 	

INSTALLATION REQUIREMENTS	
Display case must be installed level. The display case must not be installed in any area where it may be affected by steam, grease, dripping water, high temperatures, or any other severely adverse conditions.	
Do not install a heated display case near a cold air source such as a freezer, air conditioning vents, or in any area where outside air fluctuation can affect performance.	

WEIGHT		
MODEL	NET	SHIP
PD2SYS-96	740 lb (336 kg)	885 lb (401 kg)
CRATED DIMENSIONS (EST.): H X W X D		
107" x 51" x 57" (2718mm x 1295mm x 1148mm)		

OPTIONS & ACCESSORIES			
<input type="checkbox"/> BUTTING KIT	CONTACT FACTORY	PLATFORM SCALE	
<input type="checkbox"/> CARVING STATION	5001874	<input type="checkbox"/> LEFT-SIDE	5005338
<input type="checkbox"/> GAUGE, INTERIOR AMBIENT TEMP.	GU-33384	<input type="checkbox"/> RIGHT-SIDE	5005337
<input type="checkbox"/> GLASS, TEMPERED END PANE, BRONZE KIT	5008531	SHEET PAN DIVIDER BAR PACKAGE	
<input type="checkbox"/> INDEPENDENT ELECTRICAL OUTLET	5001781	<input type="checkbox"/> FULL-SERVICE CASES	5002805
PANEL KIT, SYSTEM		<input type="checkbox"/> SELF-SERVICE LEFT-SIDE OR RIGHT-SIDE OF CASES	5002806
<input type="checkbox"/> BRUSHED STAINLESS STEEL	5005146	<input type="checkbox"/> TEMPERATURE PROBE	5004918
<input type="checkbox"/> CUSTOM COLOR	5005149	<input type="checkbox"/> THERMOSTAT GUARD COVER PLATE	5007660